

External Condensate Pump Option

Installation and Operating Manual



READ THESE INSTRUCTIONS BEFORE ATTEMPTING TO INSTALL, OPERATE OR SERVICE THIS PUMP. FAMILIARIZE YOURSELF AND ANY OTHER PERSONNEL AS TO THE PUMPS LIMITATIONS AND POTENTIAL HAZARDS. OBSERVE ALL SAFETY PRECAUTIONS. FAILURE TO COMPLY WITH THESE INSTRUCTIONS COULD RESULT IN PROPERTY DAMAGE OR PERSONAL INJURY.

Only a qualified air conditioning technician should install this pump.

NOTE: It is recommended that an auxiliary drain pan be included under the unit and external condensate pump.

Inspection of Pump

Upon receipt of the pump, inspect for visible or concealed damage. Report any damage to the carrier and file a claim.

Description

This is an automatic condensate pump with ½ gallon capacity for use with air conditioners. It is controlled by a float switch that activates the pump when the depth of condensate in the sump reaches approximately 2-1/4". The pump will cycle off when the condensate level in the sump drops to approximately 1-1/4".

Features

- Leak proof, Rustproof ABS Sump
- Built in Mounting Tabs
- Three (3) Drain Holes
- Stainless Steel Motor Shaft
- Barbed Discharge Connection
- Built in Check Valve
- 6' Power Cord w/ Grounding Plug
- UL / CSA Listed
- Thermal Overload Protected
- Liquid Temperatures Up To 120° F (**)
- ABS Housing, Cover and Volute

Safety and Cautions

1. Pump must be used only with liquids that are compatible with the pump components.
2. Do not use in an explosive or caustic environment.
3. Do not handle pump while standing in water or on a damp surface.
4. Do not handle pump with wet hands.
5. Pump is supplied with a grounding plug. Plug must be connected to a properly grounded receptacle.

Condensate Drain Connection

The drain line coming off the unit must be trapped before it enters the pump sump. The drains are located on the negative side of the blower(s). The purpose of the condensate trap is to neutralize the negative pressure created within the cabinet / drain pan by the blower.

Some units may contain two drain outlets. It is only necessary to use one drain connection. Make sure the drain connection not being used is plugged.

The negative pressure can vary from less than 1" up to 2" of water column. The condensate trap must be of sufficient depth in water column to permit the condensate to flow from the drain pan.

The "A" dimension must equal or exceed the negative pressure developed by the supply air blower. The trap must be at least 2-1/2" deep to

maintain a water seal under all operating conditions, especially during blower start-up.

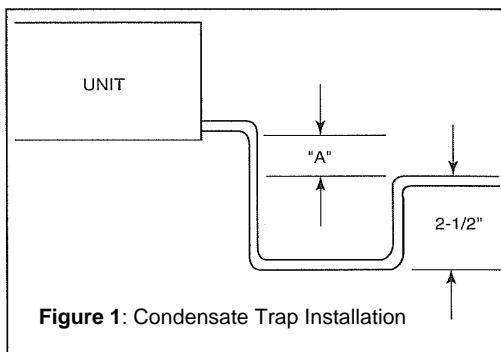

NOTE: It is recommended that the air conditioner be run through several cycles to generate condensate and collect in a separate container. This helps to flush any residual oils that may be in the system.

Installation

CAUTION: Failure to support the pump during assembly and installation may cause piping to break, pump failure or motor bearing failure.

CAUTION: Pump should not be placed inside an air plenum.

NOTE: Make sure the location selected will not exceed the pump shut off limitation of 20 feet.

1. Remove the cardboard tab from the motor cover. This tab prevents switch movement during shipment (Ref. Fig. 2).

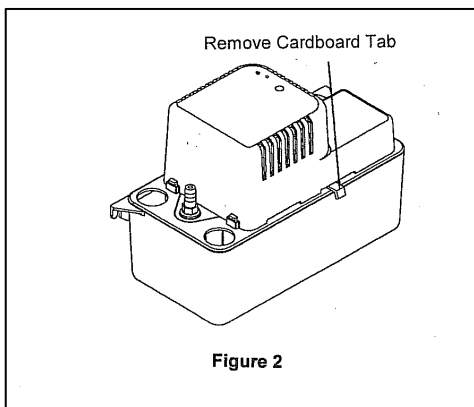

2. Mount the pump using the two slots located on the ends of the tank. (Ref. Fig. 3) Make sure the pump is level and is located sufficiently below the drain to accommodate the trap.

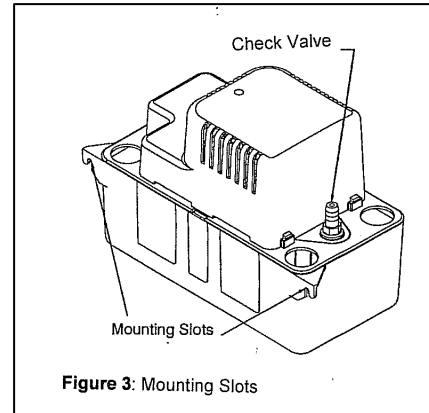

NOTE: Make sure if pump will be mounted on the side of a unit or on a wall, that the mounting surface and mounting means is sufficient to hold the weight of the pump and a full sump.

3. Make sure the location of the pump will not permit it being splashed or sprayed during unit operation, maintenance or housekeeping.
4. Route tubing from the condensate trap to one of the pump inlets. Extend the tubing into the sump from 1 to 3 inches. Make sure the condensate line does not interfere with the float. Cut an angle on the inlet tube so that it does not close off against the bottom of the sump (Ref. Figure 4).

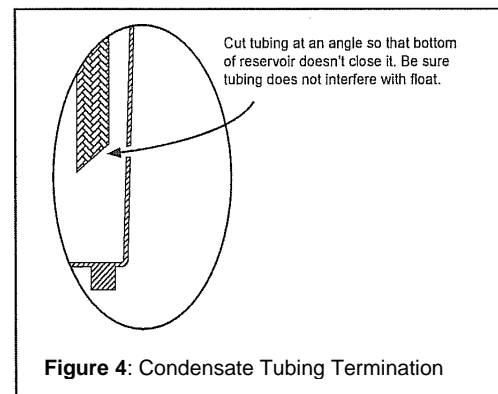

5. Connect tubing (3/8 inch ID maximum) to the check valve on the pump. Secure with a pipe clamp (field supplied).
6. Extend the tubing up as high as necessary (do not exceed head of pump at 20 feet). Properly support the tubing so that no kinks or drooping occurs. Make an inverted "U" trap at the highest point (Ref. Fig. 5).

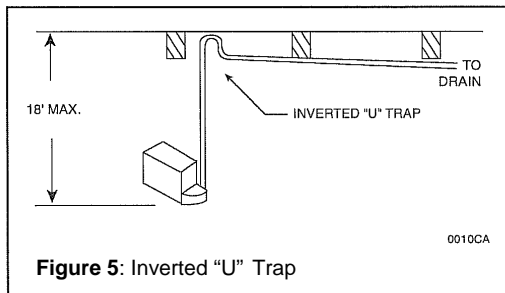

7. From the inverted "U" trap, slope the discharge line down to the drain area. Properly support the tubing so that no kinks or drooping occurs. Tubing should terminate at a point below the bottom of the pump. This will provide a siphoning effect, which will improve the efficiency of the pump.

Electrical Connections

WARNING: Electrical wiring should be accomplished by a qualified individual or an electrician.

NOTE: All wiring must comply with National and Local Codes.

WARNING: Make sure power to the unit is turned off and locked out before making any electrical connections.

1. The safety switch should be connected to the identified terminals in the United CoolAir unit. The "NC" connection is to be tied into the unit for shut down in the

event that the safety switch is activated (Ref. Fig. 6).

2. The "NO" connection can be tied into a remote alarm (field supplied) (Ref. Fig. 6).

NOTE: Use 20 or 22 Gauge thermostat wire for the connections to the "NC" or "NO" circuits.

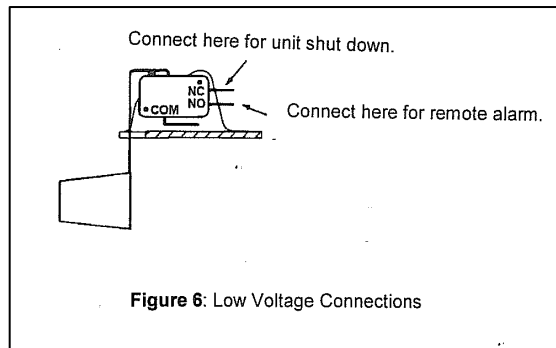

3. Connect the power cord to a properly grounded receptacle matching the line voltage specified on the motor and nameplate. Power cord must be connected to a constant power supply, not a switched circuit that would be intermittent.
4. Restore power to air conditioner.
5. Verify that the pump is functioning by observing several cycles.

() – If unit contains a steam canister humidifier contact the factory for an alternate pump that can handle the higher water temperature.**

Specifications

Horsepower	1/30
Power Cord	6'
Voltage	115-1-60
Amps	1.5
Watts	93
Shut Off	20'
Weight	5 Lbs. (Empty Sump)

Performance

Feet	GPH
1	80
5	70
10	48
15	24
20	0

Dimensions

