

C-Series™

- Horizontal Self-Contained or Split Systems
- 1 to 15 Tons
- Air-Cooled, Water-Cooled, Heat Pump or Chilled Water

Available with
R-410a
Refrigerant



United
CoolAir Corp™

www.unitedcoolair.com

C-Series Split-Able Air Conditioning System

Ultra-Flexible Split-able Air Conditioning Systems

The C-Series furnishes design engineers and contractors with one of the most versatile air conditioning systems available today! The horizontal configuration is designed for ceiling or slab mounting, and provides uniform airflow through supply-side ducting.

The C-Series can be used as a packaged unit or as a split system with the evaporator and condensing sections in different locations up to 250 equivalent feet* away. By locating the condensing section near an outside wall, ducting can be minimized and installation is easier (especially for replacement or renovation jobs).

Heat rejection options include air or water with the added benefit of chilled water and heat pump configurations. The C-Series includes components for dependable operation and a long list of options for a custom-tailored system.

Applications

- Offices
- Retail Spaces
- Schools
- Industrial
- Areas separate from main locations
- Add-ons
- Electrical equipment rooms
- Limited access areas
- Renovations
- Replacements

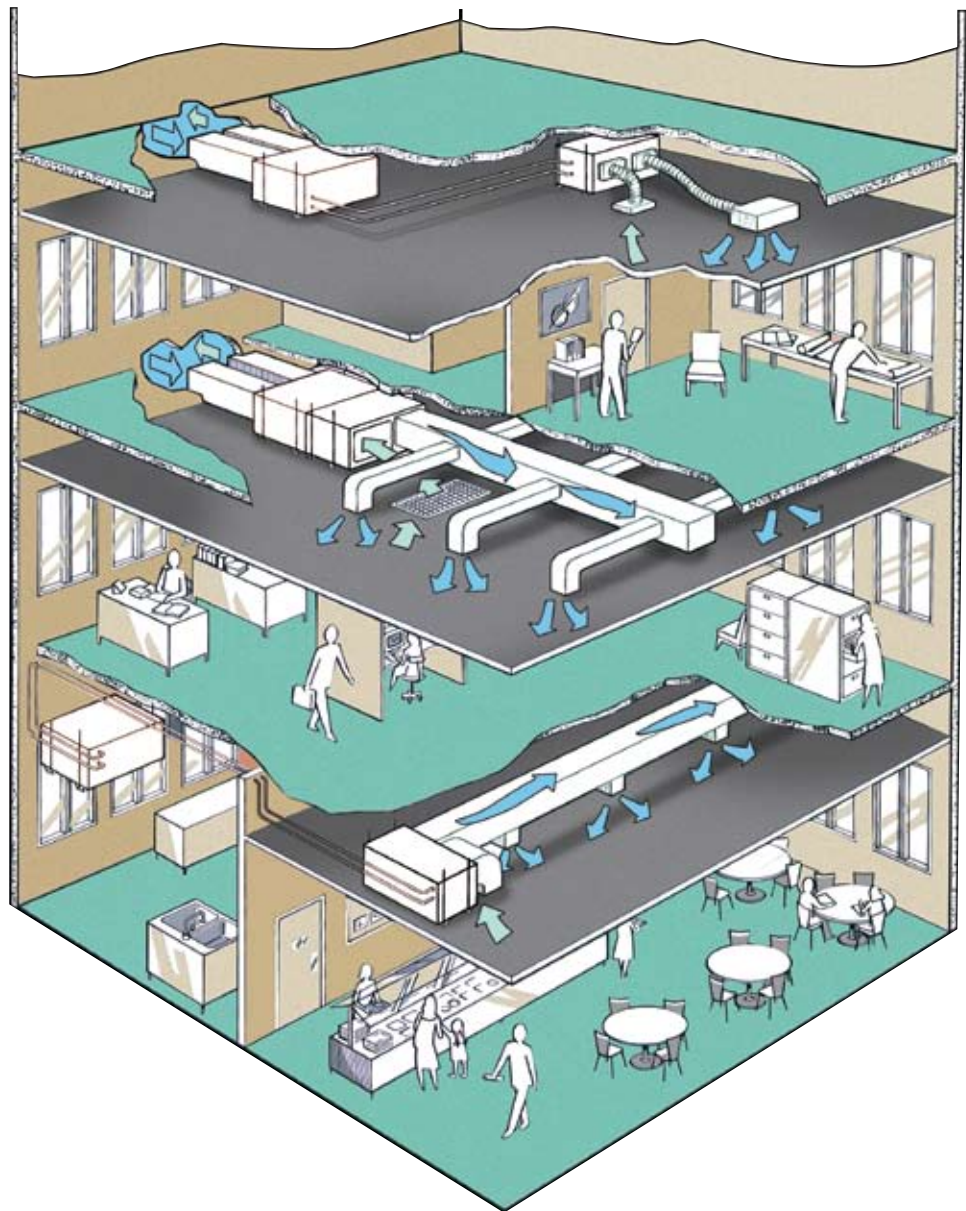

C-Series is available in 4 cabinet sizes to suit your application.

* Will require refrigerant circuit options

C-Series Features



Split-able Design Allows Greater Installation Flexibility

The C-Series with its unique split-able design allows the condensing section installation up to 250 equivalent feet* in any direction away from the evaporator section. Now you can minimize ductwork needed to remove waste heat created by the refrigeration circuit. The condensing section can be located near an outside wall, outside air shaft or any location suitable for heat removal. The split-able feature allows additional installation flexibility in locations where space is limited such as historical structures.

Overcomes Troublesome Architectural Limitations

The C-Series easily overcomes architectural limitations such as sloped roofs, limited mounting space and remote locations that present challenges to the air conditioning contractor. This is especially prevalent in renovation and historical installations where appearance is critical and building codes are strict. The C-Series is also ideal for high security installations because it allows for equipment placement in areas away from tampering and vandalism.

Variable Pitch Pulleys
Operation across wide external static pressure range

Removable Panels
Easy access to components

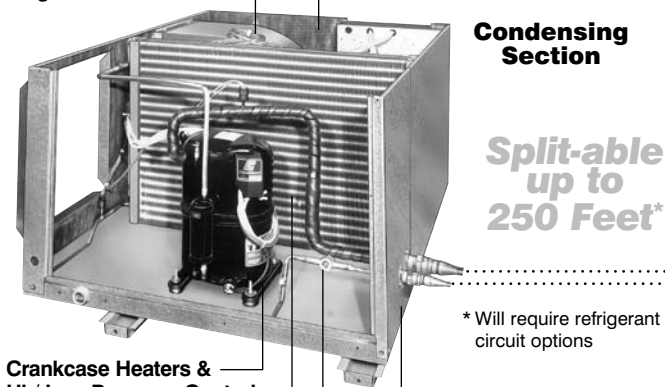

Crankcase Heaters & Hi / Low Pressure Controls
Provides protection for compressors

Oversized Coils
Low air flow pressure drop

Sight Glass / Moisture Indicator
Visual indication of refrigerant charge & quality

Galvanized Steel Cabinet
Corrosion-resistant construction

Oversized Transformers
Stable control voltage

Dual Electrical Control Panels
Allows independent wiring when split

Air Flow Switch
Protection for electric heat applications

Thermal Expansion Valve
Provides stable operation across various conditions

Evaporator Section

Filter Drier
Removes any moisture or contaminants

Stainless Steel Drain Pan
Non-corrosive condensate disposal

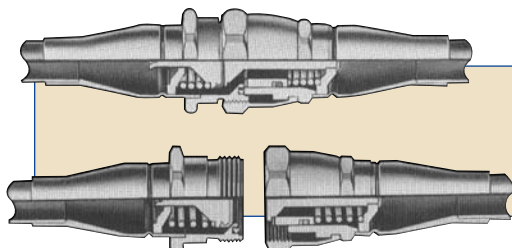

The optional Interconnect Kit permits the refrigeration circuit to be field split without the loss of factory charge. The kit includes reusable quick-connect fittings that are used in conjunction with field-supplied tubing to complete the refrigeration lines between the two sections.

C-Series Horizontal

1 - 15 tons

- **Air-Cooled**
- **Water-Cooled**
- **Chilled Water**
- **Heat Pump**

The C-Series Horizontal unit is designed as a flexible ducted air conditioning system for commercial cooling applications. The ideal system for new construction, replacement or renovation. The low profile design is available in four cabinet sizes starting at 16" high and with a cooling capacity up to 15 tons. Units 6 tons and higher come with multiple compressors* for staged operation, greatly reducing power consumption when full tonnage is not required.

* 4 and 5 ton available with single or dual compressors.



Fits through 29" doors

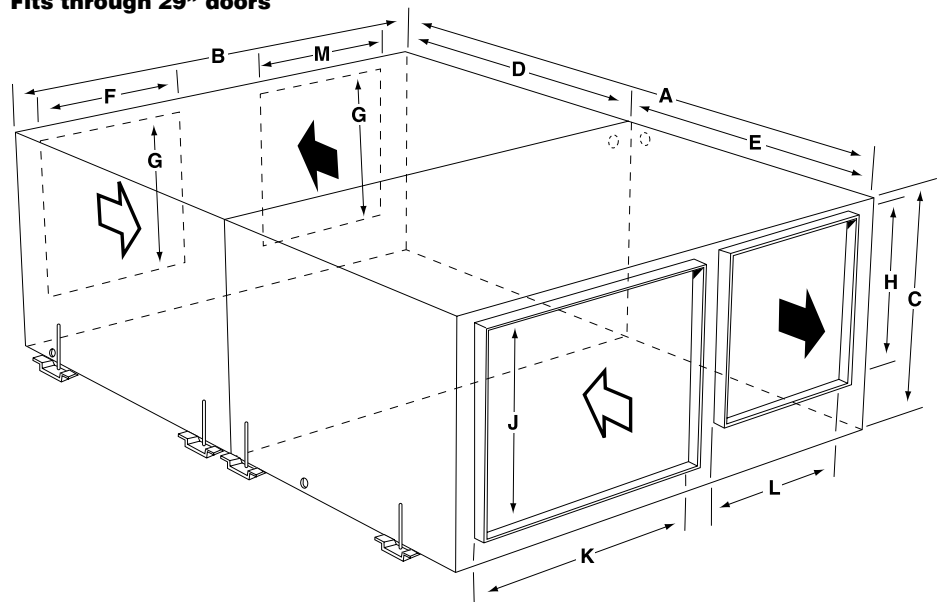

Dimensions - Inches (Air-Cooled or Water-Cooled)

NOMINAL TONS	A	B	C	D	E	F	G	H	J	K	L	M
1 & 1-1/2 Ton												
Single Compressor	51-3/4	35-13/16	16	29-3/8	21-7/8	12	12	12	12	16	12	12
2, 3, 4 & 5 Ton												
Single Compressor	66-1/8	47-1/4	22	34-3/4	31-3/8	16	16	16	18	24	16	16
4, 5, 6 & 8 Ton												
Two Compressors	77-5/8	55-1/4	27	40-1/4	31-3/8	18	20	18	23	32	16	18
10 Ton												
Two Compressors	80-7/8	70-3/8	29	45-1/8	35-1/2	30	24	20	25	38	18	20
12 & 15 Ton												
Three Compressors	80-7/8	70-3/8	29	45-1/8	35-1/2	30	24	20	25	38	18	20

C-Series Vertical Stacking

1 - 15 tons

- Air-Cooled
- Water-Cooled
- Heat Pump



The C-Series Vertical Stacking unit configuration is designed for installations where floor space is minimal and a ceiling space is not available. Floor space requirements are reduced by placing the evaporator section above the condensing section, allowing the unit to be placed into utility rooms, alcoves and equipment rooms. Evaporator discharge air is available through the front, top or in a straight through configuration. A rigid frame system supports the evaporator and provides vibration free operation.

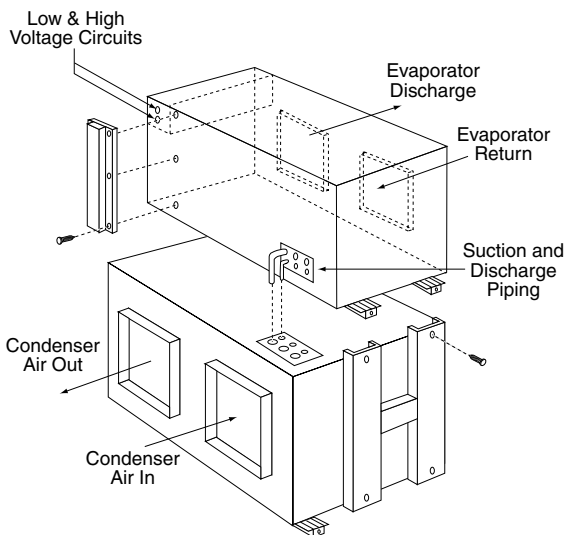

Right Side View

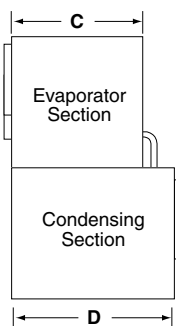

Rear View

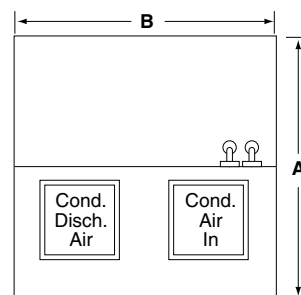

Top View

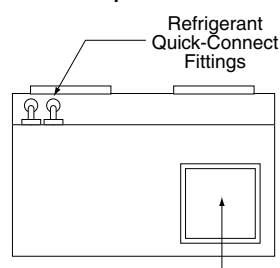

Alternate Evaporator Discharge Air Opening on Cabinet Top

Front View

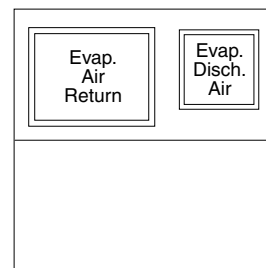

Dimensions - Inches (Air-Cooled or Water-Cooled)

NOMINAL TONS	A	B ⁽¹⁾	C	D
1-1.5 TON				
Single Compressor	34	40 1/2	21 7/8	29 3/8
2-5 TON				
Single Compressor	46	52	31 3/8	34 3/4
4-8 TON				
Two Compressors	56	60	31 3/8	40 1/4
10 TON				
Two Compressors	60	75	35 1/2	45 1/8
12 & 15 TON				
Three Compressors	60	75	35 1/2	45 1/8

(1) Includes frame



C-Series Features

Cabinet

Galvanized steel construction using a full stainless steel drain pan on the evaporator section. Unit is mounted on channels to accommodate hanging rods for ceiling/slab floor mounting.

Evaporator and Condenser

Oversized coils for low pressure drop and reliability using draw through airflow design with extremely large face areas and multiple rows.

Motors and Blowers

Ball bearing construction with keyed shafts and pulleys. Variable pitch pulley design provides flexibility in external static pressure requirements. The 2-15 ton unit motors have a rigid base and are mounted on adjustable motor mounts.

Refrigeration Circuits

Equipped with heat pump-duty compressors and adjustable expansion valves with external equalizers, sightglass/moisture indicators and filter driers. Includes reusable quick-connects that permit the refrigeration circuit to be field split without the loss of the R-410a factory charge.

Electrical

Independent electrical control panels in the evaporator and condensing sections allow the sections to be wired independently when field split (single power supply only for non-split packaged units). Separate oversized transformers in each section eliminate low voltage control problems over long splits. All reciprocal compressors are equipped with crankcase heaters and are protected by high and low pressure controls in the circuit. An air switch on the evaporator blower provides added safety when electrical heat is included. Each individual component has its own contactor.

Multi-Stage Operation

Improves operating efficiency by reducing power consumption when full tonnage is not required. Available on 4 to 10 ton units (two compressors) and 12 to 15 ton units (three compressors).

Serviceability

Units are designed for easy serviceability using removable side panels for fast installation, inspection and service of all internal parts without the need to lower or dismantle the unit. Schrader valves are provided in the condensing section for field testing.

C-Series Partial List of Options

- Electric Heat
- Electric Reheat
- Condensate Pump
(Factory Installed and Wired)
- Drain Pan Overflow Switch
- Compressor Short Cycle Timer
- Freezestat
- Dry Contacts
- Steam Canister Humidifier
- Upgraded Motors, Evaporator or Condenser
- Pillow Block Bearings
- Flooded Condenser (Down to -30°F)
- Winter Start Kit for Flooded Condenser
- Outdoor Modification Kit
- Hot Gas Bypass
- Modulating Hot Gas Bypass
- Microprocessor Controls
- Scroll Compressor
- SCR Control
- Quench Valve
- Oil Separator
- Liquid Receivers
- Economizer (Air or Water)
- Mixing Box
- Double Wall
- External Filter Box
- Mirror Image
- Vertical Stacking
- Straight Thru Air Path
- Chilled Water Coil
- Hot Water Coil
- Steam Coil
- Hot Gas Reheat
- Suction Accumulator



Proudly Made
in the USA

FACTORY TESTED - Each unit is functionally run-tested to verify control and component operation.

LIMITED WARRANTY - United CoolAir units are backed by a 1 (one) year limited warranty on parts and a 5 (five) year limited warranty on the compressor (labor not included). Maintenance items such as filters and belts are excluded under this limited warranty.

491 East Princess Street, York, PA 17403 Toll Free 1-877-905-1111 Phone (717) 843-4311 Fax (717) 854-4462
e-mail: uca@unitedcoolair.com www.unitedcoolair.com